

# Disassembly & Recycling Manual

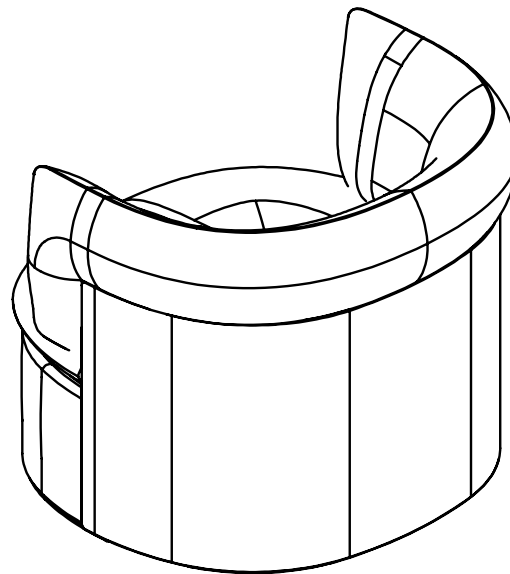

# Part Key

Part	Qty	Material
A Back Pillow	1	PU Foam   Nylon   PET   Fabric
B Seat Cushion	1	PU Foam   Nylon   PET   Fabric   Latex
C Shell	1	Plywood   Nylon   PET^   Fabric^   Steel
D Plinth	1	Plywood   PU Foam   PE Foam   PET   Fabric
E Bracket	4	Steel
F Swivel	1	PET   Steel   Aluminum
G Glide*	4	PET   Nylon   Steel
H Caster*	4	PET   Nylon   Steel

\* See pg 8

^ Upholstered shell only

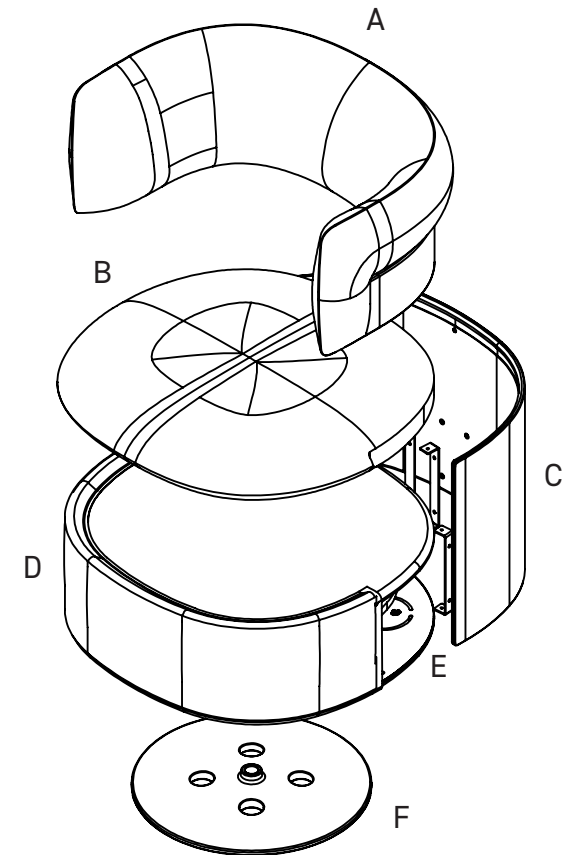

# Hardware Key

Part	Qty	Material
H1 Cleat	2	Nylon
H2 Woodscrew	2	Steel
H3 Button head screw	8	Steel
H4 Washer	8	Steel
H5 Button head screw	8	Steel
H6 Nut	8	Steel
H7 Flat head screw	4	Steel
H8 Pan head screw*	4	Steel
H9 Pan head screw^	16	Steel

\* Glide models only  
 ^ Caster models only

## Recommended Tools

- 1 Safety glasses
- 2 #2 Phillips head screwdriver
- 3 3/16" Allen wrench
- 4 Mallet

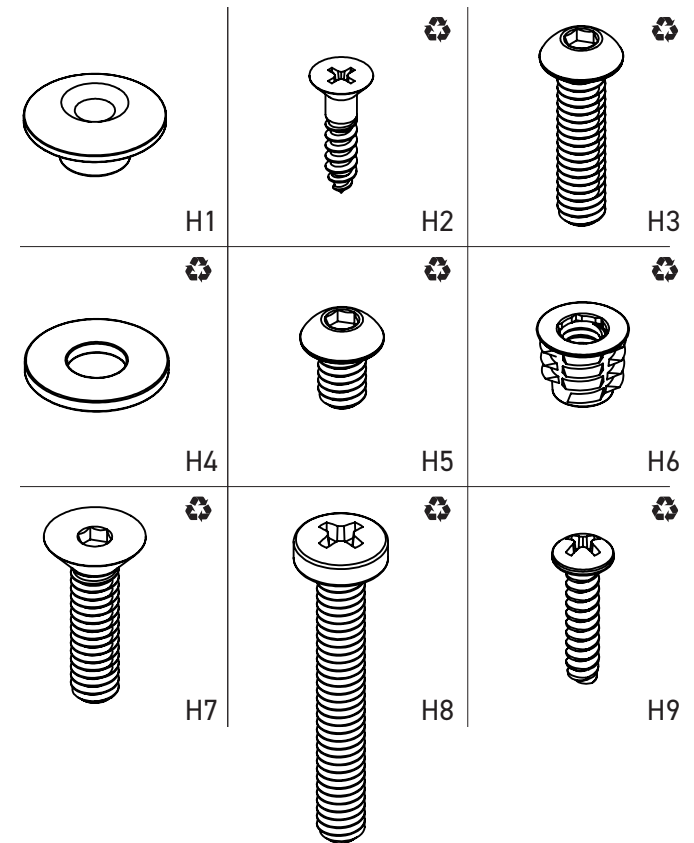

## I | Back Pillow + Seat Cushion

---

**A** Locate start of zipper behind the right side of the back pillow. Use zipper pull to unzip and release the back pillow from the shell. Note: unzipping is made easier by applying downward pressure along the top edge of the back pillow.

**B** Untoggle the seat cushion's elastic loops from the H1 cleats, located on the left and right side of the shell interior. Release the seat cushion from the plinth. Remove H2 screws to separate the H1 cleats from shell.

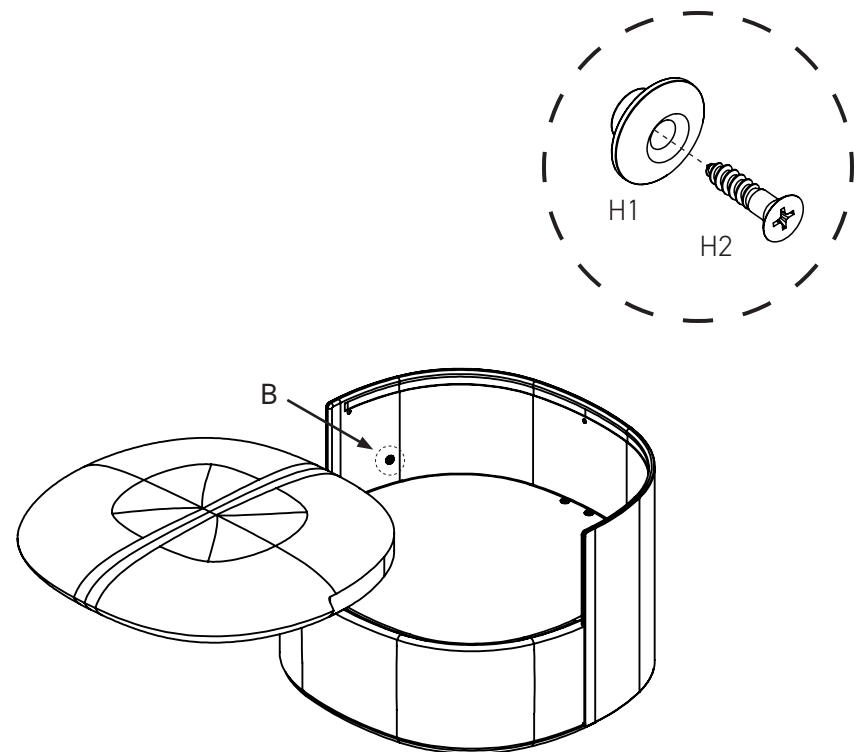
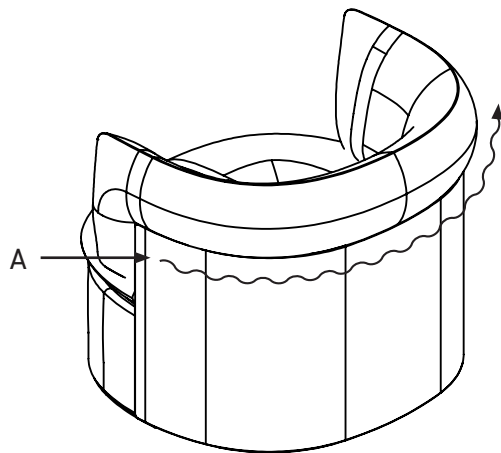

## II | Shell

---

**A** Tilt chair backward onto shell to access and remove the H3 screws and H4 washers (x4) from the bottom of the plinth.

**B** Return chair to upright position and remove the remaining H3 screws and H4 washers (x4) from the top of the plinth. Pull shell backward to release.

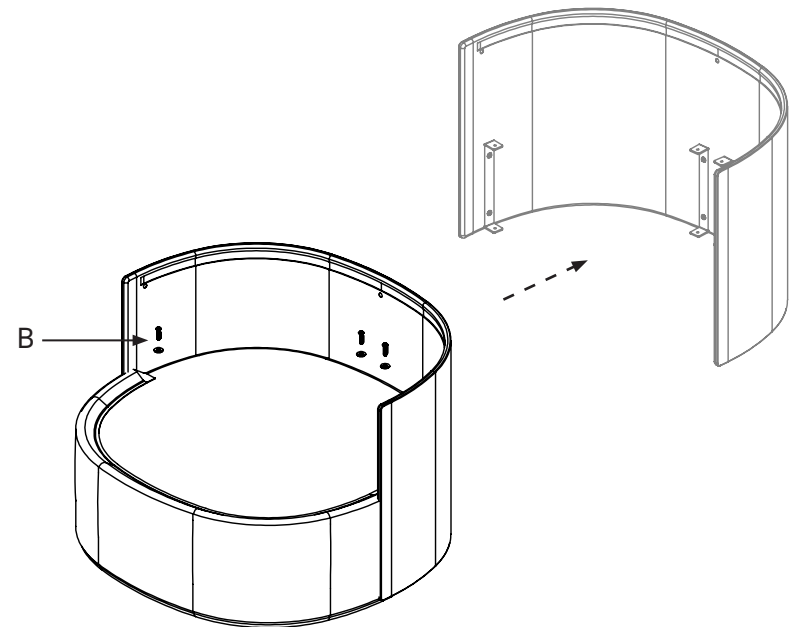
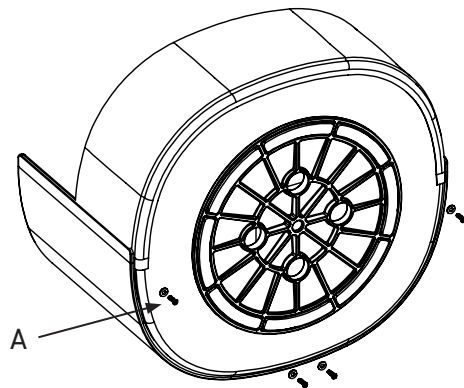

### III | Brackets + Spring

---

**A** Remove the H5 screws (x8) to release the recyclable steel brackets (x4) from the shell. Remove the remaining H6 nuts (x8) embedded in the shell.

**B** Cut into the decking fabric located on the top of the plinth to access and remove the recyclable PET spring located inside.

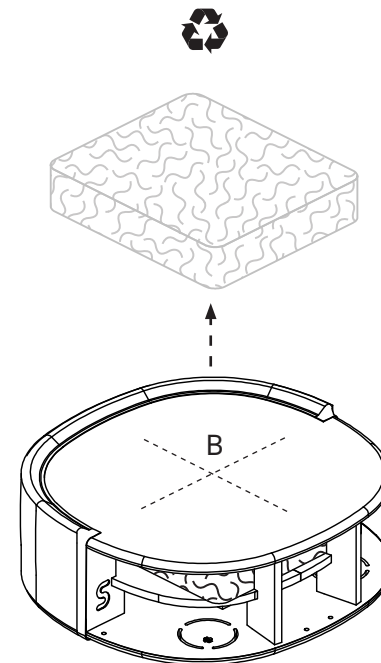
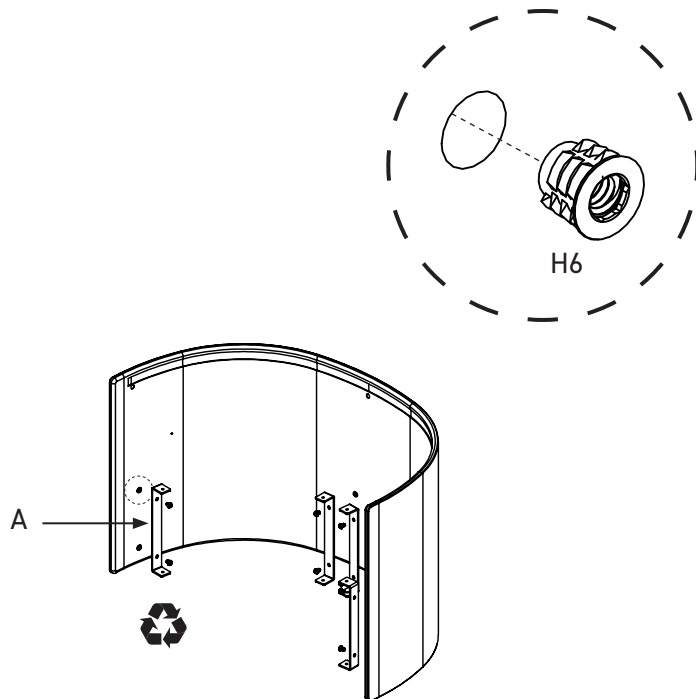

## IV | Swivel Base

---

**A** Position plinth upside down and rotate swivel base to align the four large holes with the screws in the mounting plate. Remove H7 screws (x4) from the mounting plate to separate the swivel assembly from the plinth.

**B** Knock the mounting plate out from the swivel base.  
Note: this step is made easier by propping the swivel base up on two sides so that the mounting plate is elevated above the work surface. Remove felt glides from swivel base prior to recycling.

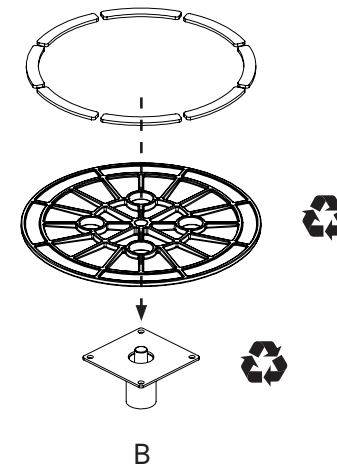
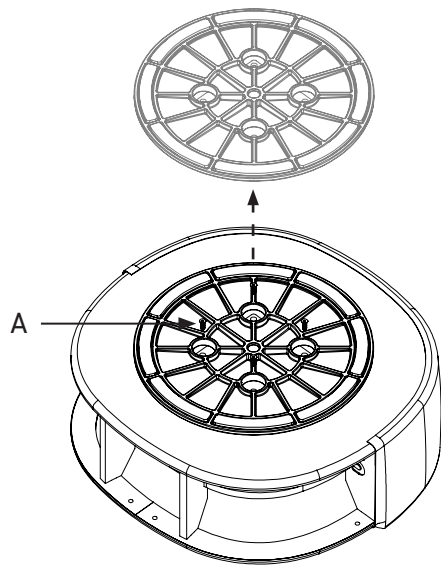

## V | Glides + Casters

---

**A** If your chair is equipped with glides, remove the H8 screw located inside each glide (x4); for glides with felt or rubber inserts, pry off insert first.

**B** If your chair is equipped with casters, remove the H9 screws (x4) located inside each caster housing (x4). Once the casters are removed, release the caster housing (x4) by prying off from the plinth.

